

COIL ROOFING NAILER

Model: UNCR45

APPLICABLE FASTENER SIZE

Shank Dia.: .120"

Head Dia.: .335"

Length: 7/8" ~ 1-3/4"

Shank Type: Smooth/Ring

APPLICATIONS:

Asphale & fiberglass, shingles, siding, construction paper, metal drip edges, insulated sheathing, upholstery panels.

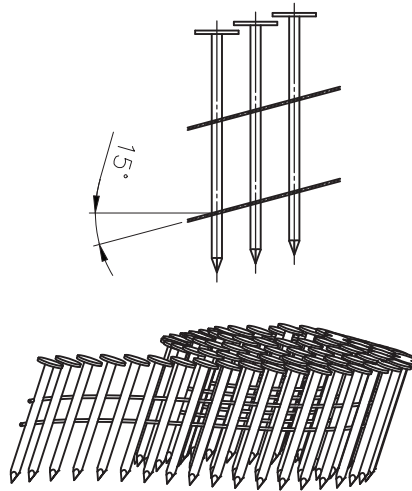

TOOL SPECIFICATION

Weight:	Dimensions:	Load Capacity:	Operating Pressure:
6.16lbs / 2.8kgs	10.5 x 4.5 x 11" 267 x 114 x 279MM	120 nails	70~100 psi (5~7 bar) Do not exceed 120 psi